

COMPACT 10/12 DX



- Compact and highly manoeuvrable
- Increased working area.
- Excellent gradeability (40%).
- Standard 4 wheel drive.



COMPACT 10/12 DX

Rough-terrain scissor lifts

The Haulotte® advantages

- Hydraulic differential lock for improved rough terrain traction
- Full proportional controls
- Robust, reliable and easy to maintain design
- Tight turning radius provides excellent manoeuvrability

STANDARD FEATURES

- Deutz engine
- 4 wheel drive with 2 front steer wheels
- 3° Tilt alarm
- 1,2m (47 in) platform extension
- 12V - 70 Ah Batteries
- Removable operator's control box
- Free wheeling device
- Hourmeter
- Towing hooks / lifting eyes
- Hydraulic brakes
- Manual emergency lowering control at ground level
- Foam filled all terrain tyres
- Side protection
- Horn
- Safety harness anchor points

OPTIONS & ACCESSORIES

- Rotating beacon
- Power line in cage
- Collapsible handrails
- Automatic levelling outriggers
- Work light
- Catalytic exhaust
- Biodegradable oil
- Motion alarm for movements and translation
- Non-marking tyres
- Cold weather kit

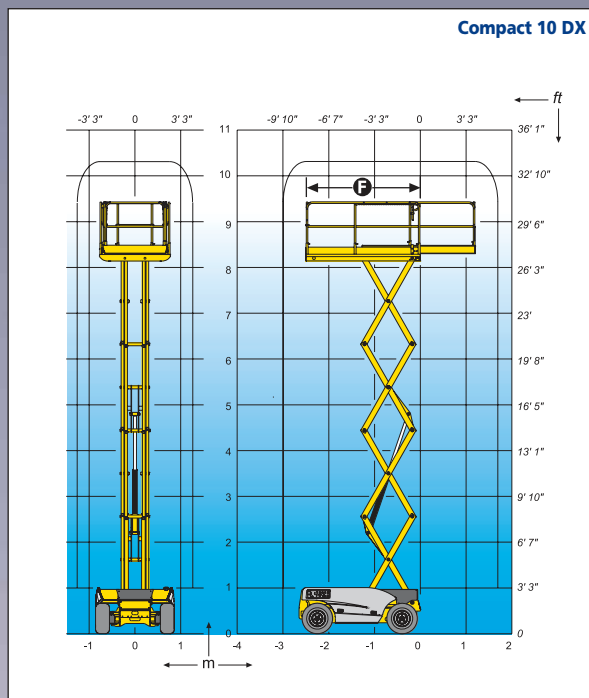
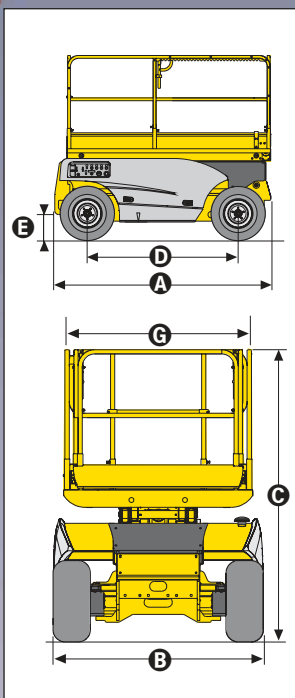

SPECIFICATIONS

	Compact© 10 DX		Compact© 12 DX	
Working height	10,2 m	33 ft 5 in	12.15 m	40 ft
Platform height	8,2 m	27 ft	10.15 m	33 ft 3 in
Platform capacity	565 kg	1,245 lb	450 kg	992 lb
A Length	2,65 m - 8 ft 8 in			
B Width	1,80 m - 6 ft			
C Stowed height (guardrail)	2,37 m	7 ft 10 in	2,54 m	8 ft 4 in
Stowed height (platform)	1,5 m	4 ft 11 in	1,68 m	5 ft 6 in
D Wheelbase	1,87 m - 6 ft 1 in			
E Ground clearance	25 cm - 10 in			
F x G Platform size	2,5 x 1,54 m - 8 ft 2 in x 5 ft 1 in			
Platform extension	1,2 m - 47 in			
Drive speed	0,8 / 5,5 km/h - 0,5 / 3,4 mph			
Outside turning radius	3.73 m - 12 ft 3 in			
Inside turning radius	1,45 m - 4 ft			
Lift / lower speed (s)	35 / 40 sec.		40 / 45 sec.	
Power source	Deutz 18kW - 24.5 hp			
Gradeability	40%			
Brakes	Hydraulic			
Tyres (foam filled)	26 x 12-12			
Hydraulic tank	80 l - 17,6 gal			
Fuel tank	30 l - 6,60 gal			
Weight	3 330 kg	7300 lb	3 830 kg	8580 lb

AS1418.10



HAULOTTE UK LTD • Stafford Park 6 - Telford - Shropshire TF3 3AT - UK • Tel : +44 (0)1952 292753 • Fax : +44 (0)1952 292758 • e-mail: haulotte@haulotte.co.uk
 HAULOTTE SCANDINAVIA AB • Aröds Industriväg 66B - 422 43 Hisings Backa - SWEDEN • Tel : +46 31 744 32 90 • Fax : +46 31 744 32 99 • e-mail: hwallin@haulotte.se
 HAULOTTE AUSTRALIA PTY LTD • 65 Licola Cres - Dandenong - VIC - 3175 - AUSTRALIA • Tel : +61 (0)3 9706 6787 • Fax : +61 (0)3 9706 6797 • e-mail: sales@haulotte.com.au

Haulotte 
GROUP

Haulotte Group - La Péronnière - BP 9 - 42152 l'Homme - France • Tél : +33 (0)4 77 29 24 24 - Fax : +33 (0)4 77 29 43 95
 e.mail - haulotte@haulotte.com • web : http://www.haulotte.com